

# ALTENBURGER ELECTRONIC GMBH

77960 Seelbach, Schloßweg 5, Telefon 07823/509-0, Fax:07823/2761  
email: [info@altenburger.de](mailto:info@altenburger.de) Internet: <http://www.altenburger.de>

## MANUAL

### MULTI-SENSOR-Control MSL

Maximum/Minimum light level setting with presence detection

TYPE: MSL, ORDER-NO: 50.13.510 AND TYPE MSL/K, ORDER-NO: 50.13.511

#### Range of Application and characteristics of the control

The MSL is suitable for the adjustment of two different light levels (maximum/minimum) and presence detection. The lighting changes between the 2 light levels according to the presence detection: if motion is detected the set maximum light level is achieved, if no motion is detected the control changes to the minimum set light level. With the selection switch fixed light levels or daylight dependent light values can be selected.

The MSL is suitable for the direct control of fluorescent lamps with electronic transformers with 1-10 V interface as well as for the control of ALTENBURGER dimmers via its 0...10V interface (controlling incandescent lamps, high-voltage lamps, low-voltage lamps with wire-wound, electronic transformers or transformers with 1-10 V interface), neon lamps. Finally the MSL also can be used directly for the presence detection.

#### Functions to be selected by the selector switch (point 4)

The selector switch can be operated in steps. The normal position arrow is a vertical one (is shown in the drawing). It is switched clock-wise.



#### Light value reduction (Pos.0)

(a deactivation of the presence detection could be made with an external switch)

- **Function:** the light level reduction provides for a preset maximum light level as soon as presence is recognized. If no motion is detected the room lighting would go after an adjustable delay time into the minimum light level which also can be adjusted. If motion again is detected lighting goes into the originally set maximum light level.
- **Adjustment:** with the 'maximum' pushbutton (1) the light level is to be adjusted which shall be achieved as soon as presence is detected. With the 'minimum' pushbutton (2) the minimum light level is adjusted which is achieved after no presence is detected. Within 10 sec. after the last setting of one of the 2 pushbuttons (maximum and minimum) the adjusted light levels are stored. These light levels are automatically achieved after presence is detected or no longer detected.
- **Optional external operation devices:** at terminal B (7) a switch or time switch can be connected against chassis (6). As soon as the contact is closed lighting also would not be reduced if presence is detected. This is applicable if in a room where just a few persons are present and if not enough sensors are installed so that gaps in the identification could occur.



#### Light value reduction (Pos. 1)

(Control with an external pushbutton)

- **Function:** as above (position 0)
- **Adjustment:** as above (position 0)
- **External controls (optional):** at terminal B (7) against chassis (6) a pushbutton can be connected. With this pushbutton the lighting can be operated as follows:
  - a) continuously pressing (> 400 ms) lighting will be dimmed brighter and darker.
  - b) with a short pressure (< 400 ms) lighting will be switched ON/OFFThe last set light level is maintained as long as presence is detected. If no presence is detected after the set delay time lighting goes into the minimum set light level as long as it is switched ON. If the lighting was switched OFF it remains 'OFF'. Only if presence again is detected the lighting switches ON again and goes into the maximum set light level.



### Lighting control with motion detection (Pos. 2)

(with an optional deactivation of the presence detection with an external switch)

- **Function:** the lighting control operating according to presence detection adjusts after the detection the preset maximum light level. If no presence is detected lighting smoothly is reduced to the minimum set light level within the set delay time and finally switches OFF after 10 min. As soon as movement is recognized again lighting switches again into the set maximum light level.
- **Adjustment:** with the pushbutton 'Maximum' (1) the light level is adjusted which shall be achieved after presence detection. 10 secs after the last operation of the pushbutton the adjusted light level is stored. The MSL is in the normal operation- al mode.
- **Optional external operation devices:** at terminal B (7) a switch or time switch can be connected against chassis (6). As soon as the contact is closed lighting also would not be reduced even if presence is not detected. This is applicable if in a room where just a few persons are present and if not enough sensors are installed so that gaps in the identification could occur. If no presence is detected light would be reduced to minimum and finally switched OFF.



### Lighting control with motion detection (Pos. 3)

(optional control with an external pushbutton)

- **Function:** as position 2
- **Adjustment:** as position 2
- **Optional external controls:** at terminal B (7) against chassis (6) a pushbutton can be connected. With this pushbutton the lighting can be operated as follows:
  - a) continuously pressing (> 400 ms) lighting will be dimmed brighter and darker.
  - b) with a short pressure (< 400 ms) lighting will be switched ON/OFFThrough a double click (2xshort tipping) the set light level is stored. If it is not stored the manually set light level is maintained as long as presence is detected. If within the adjusted delay time no presence is detected lighting is smoothly dimmed down and will be switched OFF after 10 min. If the lighting was switched OFF manually, it remains OFF. After presence is detected again the lighting goes into the stored light level or into the manually last set light level (if no value was stored).



### Daylight dependent Light level reduction (Pos. 4)

(optional with deactivation of the presence detection with an external switch)

- **Function:** the daylight dependent light level reduction adjusts a preset maximum light level as soon as presence is detected. If no presence is detected room lighting goes after an adjustable delay time to an also presettable minimum light level. As soon as presence is recognized again the maximum light level will be achieved. If the daylight portion is so high that the maximum light level (during presence detection) respectively the minimum light level (no presence detection) is exceeded the lighting slowly is dimmed down and switched OFF after 10 min.
- **Adjustment:** with the pushbutton 'Maximum' (1) the required maximum light level during presence detection is adjusted. This is measured within 10 secs after the last setting operation of the pushbutton and then stored. With the minimum pushbutton (2) the required minimum brightness is adjusted which would apply after no presence any longer is detected. Also within 10 sec. after the last operation of the pushbutton the set minimum light level will be stored. Now the MSL is in the normal operation. If the maximum as well as the minimum light level one after the other is adjusted again within 10 secs after the last operation of the pushbuttons the last set value is measured and stored again.
- **External function controls (optional):** at terminal B (7) against chassis (6) a switch or time switch can be connected. If the contact is closed lighting would not be reduced, even if no presence is detected. This is applicable if in a room just a few persons are present and if there are not sufficient sensors installed so that there are gaps in the presence detection.



### Daylight dependent light level reduction (Pos. 5)

(with an optional control with an external pushbutton)

- **Function:** as position 4
- **Adjustment:** as position 4

**External operational controls (optional):** at terminal B (7) against chassis (6) a pushbutton can be connected. With this pushbutton the lighting can be dimmed brighter/darker through continuously pressing the button (> 400 ms) and can be switched ON/OFF through short pressing the button (< 400 ms). The respective adjustment of the light level is maintained as long as presence is detected. If within the adjusted delay time no presence is detected any longer lighting goes into the minimum light level. If the lighting was switched OFF, it remains OFF. Only if presence is again detected lighting switches ON and goes into the maximum set light level (provided the daylight portion is below the set light level).



### ON/OFF Switching (Pos. 6)

Just in dependence of presence detection

- **Function:** with the integrated relay lamps (or other loads) can be switched ON and OFF in dependence of a motion detection. The relay is in function as long as motion is detected. As soon as no motion anymore is recognized the relay switches the load OFF after the set delay time.
- **No adjustment** necessary. The set maximum/minimum light levels to be set at the front of the MSL are out of function as soon as the arrow is set to '6'.
- External operational controls (optional): at terminal B (7) against chassis (6) a switch can be connected. If the contact is closed lighting would not be switched OFF if no presence is detected. This is applicable if for a short while only a few persons are in a room where not sufficient sensors are installed so that sensor gaps could occur. If a pushbutton is connected, lighting is switched ON after pressing this pushbutton.



### Extension of the area of detection

If the MSL is used only for the extension of the area of detection of another MSL the arrow position F can be adjusted. In this case the MSL has no other function as the extension of an area. A clicking noise of relay would not occur.

### Functions of the MSL

These are the function elements:

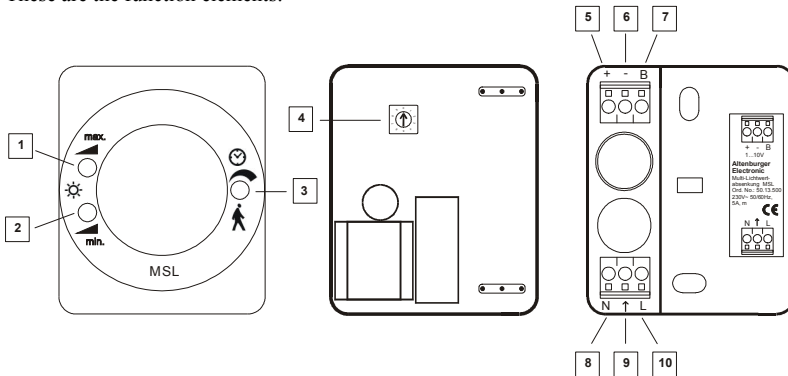

### Designations:

- (1) Pushbutton 'Maximum' for the adjustment of the required light level (high level) in case of persons being present.
- (2) Pushbutton 'Minimum' for the adjustment of the light level (low level) if nobody is present.
- (3) Potentiometer for the delay time setting (tracking time)
- (4) Selector switch for different functions.

### Terminals (also refer to the wiring diagrams)

- (5) 1 - 10 V
- (6) chassis (0 V)
- (7) terminal for the coupling of additional MSL-units and for the connection of an external switch or pushbutton (optional).
- (8) Neutral
- (9) switch contact (phase is not voltage-free)
- (10) phase

## Range of acquisition and extension of the presence detection

The moving recognition as part of the MULTI-SENSOR has an angle of acquisition of approx. 100 °, resulting in a detection range of 7 m diameter at a ceiling height of 3 m.

If larger rooms or areas jointly have to be controlled the presence detection can be amplified with max. 3 MSL controls to be coupled. Each control identifies the brightness in its area, the presence detection however occurs jointly. It is sufficient if one MSL recognizes a movement. The additional controls are only identifying the movement in order to extend the range of acquisition. In this case the selector switches can be adjusted to position 'F'. In this position the MSL's are just presence detectors.

## Construction, Assembly and wiring

The MSL can be mounted to the ceiling or it can be plugged onto fluorescent lamp tubes with an attached clip. Before mounting the device to the ceiling the base plate is drawn from the control housing and is screwed to the ceiling. The terminals of the base plate are then wired according to the wiring diagram. The MSL/K has a cable which is already pre-wired and which has just to be connected to the lamp. Before the control housing is plugged onto the base plate the required function should be set with the selector switch (4). Pos. 1 - light level reduction, optional with the control possibility with an external pushbutton is readjusted.

If the MSL should be clipped onto a fluorescent tube the lamp fixture should have a width of louvers of at least 60 mm. The clip is plugged into the base plate of the MSL and then to the tube with a diameter of 26 mm or 16 mm. In order to avoid a damage of the lamp, the clip should be placed close to an end of the tube.

## Mounting instructions

- The MSL should be mounted in a height of 2,5m - 3m. In rooms with a higher ceiling the range of detection of the movement sensor increases, the density of recognition however decreases.
- For the light level reduction in dependence of the daylight portion the adjusted brightness is measured before the set value is stored. During the measurement no person should be present directly beneath the sensor in order to avoid erroneous measurements.
- The assembly should not be made in an area with draft (e.g. a ventilator or air-conditioner) or in the neighbourhood of heat emitting devices.

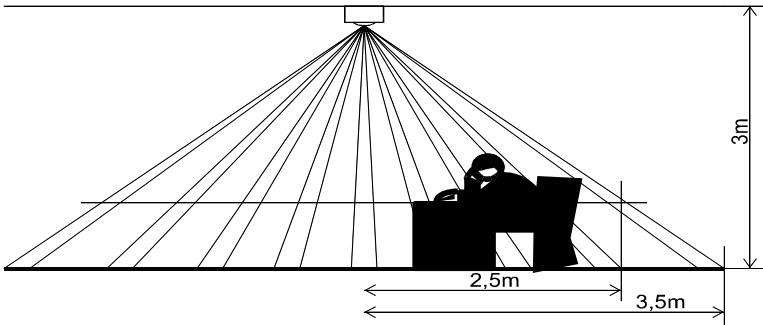

## Safety and installation requirements

- The MSL may be installed and put into operation only by skilled designated electricians.
- Wiring, mounting and other work may be performed only in a voltage-free state.
- Applicable safety instructions and regulations for the prevention of accidents have to be observed.
- For operation of the MSL in the lamp an UV-resistant cable has to be used.
- When clipping the MSL to lamp tubes an undue load must be avoided

## Adjustable functions:

Selector Switch position	Function	fixed adjusted light levels for max./min. (not flexible in dependence of the daylight)	adjusted light levels are flexible (operating in dependence of the daylight)	option: switching OFF of the presence detection through an external switch	optional: operation of the MSL with an external pushbutton
0	light-level reduction	•	/	•	/
1				/	•
2	presence detection	•	/	•	/
3				/	•
4	daylight-dependent light level reduction	/	•	•	/
5				/	•
6	presence dependent ON/OFF switching	/	/	•	/
7	n.a.				
8	n.a.				
9	n.a.				
A	n.a.				
B	n.a.				
C	n.a.				
D	n.a.				
E	n.a.				
F	Slave control (only for the extension of the range of identification)				

## Technical Data

Description and Order-No.	: Light-level reduction module type MSL, Order-No.: 50.13.510 Light-level reduction module type MSL/K, Order-No.: 50.13.511 (with 1,5m UV-resistant cable)
Power supply	: 230V~ 50/60 Hz, DC not permitted (would damage the sensor)
Protection	: external through 6A MCB or fuse
Power consumption	: approx. 2 W
Operating temperature	: 0°C.....+50°C
Adjustable light value for min.	: approx. 5-1500 Lux (directly at the MSL)
Adjustable light value for max.	: approx. 15-1500 Lux (directly at the MSL)
Angle of detection and mounting height	: approx. 100° (light and presence detector), 2.5 m – 3.0 m (optimum height for the presence detection)
Supply and load connections	: L, N, activated L (↑)
Control terminals	: +, - (1..10V or 0..10V) B (parallel wiring of the extension of the range of detection, and connection for external witches and pushbuttons) Base isolation according to IEC 664 (10/92), no protective extra low potential
Load capacity of the control output	: 1..10V - max. 100mA (approx. 100 electronic ballasts or transformers – please refer to manufacturer's specification) 0 10 V- max. 3 mA for ALTENBURGER dimmers (3 dimmers of any load capacity up to 8 KW)
Wiring	: please refer to wiring diagrams - in case of miswiring malfunction or damage possible.
Load capacity of the circuit output	: 5A ohmique load ⇒30p* electr. bal. 1 lamp 18W, 20 p* twin-electr. bal. 18 W 30p* electr. bal. 1 lamp 36W, 20p* twin-electr. bal.36 W 20p* electr. bal. 1 lamp 58W, 10p* twin-elect. bal. 58W
Decline period of control potential	: approx. 30 seconds (100% to 1%)
Lagging time if not motion is recognized	: dimming range adjustable between 1 and 30 minutes + 10 min until switch OFF
Parallel connection of controls	: max. 6 MSL (for the extension of the range of presence detection)
Protective class, protective system	: II (protective insulation), IP 20
Max. cable length	: 100 m (control wires 0,5 mm <sup>2</sup> , load and supply wires 1,5 mm <sup>2</sup> )
Terminals	: screw type terminals for single wires or litz wires 0,3 - 1,5 mm <sup>2</sup> (or usage of the 1,5 m cable at the MSL/L)
Construction	: Plastic housing for mounting on ceilings or lamp fixtures louvers
Contamination level	: 2 (dry non-conducting, according to IEC664, 10/92)
Dimensions, weight	: W x H x D = 58.5 x 70.5 x 42 mm
Weight	: approx. 150 g
Designation	: CE

\* Number of connectable electronic ballasts with 15m cable of 1.5 mm<sup>2</sup> from the distribution rack to the MSL and further 20 m to the midst of the load circuit (impedance approx. 800 mΩ). With greater cable diameters or shorter lines the permissible load would be reduced (e.g. at an impedance of 400 mΩ by 20%).

Error and technical alteration reserved.

# Wiring diagrams

1 MSL as individual module for the light value reduction. Optional: with 1 switch for the deactivation of the presence detection

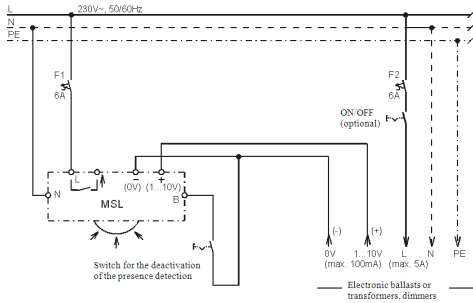

1 MSL as individual module for the daylight dependent light level reduction or as presence detection. Optional with a switch for the deactivation of the presence detection

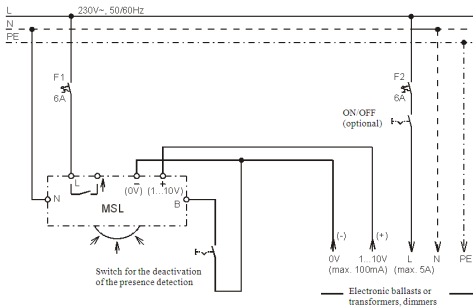

1 MSL as individual module for the light value reduction, for the daylight dependent light level reduction for the presence detection. Optional with 1 pushbutton for the external control of the MSL

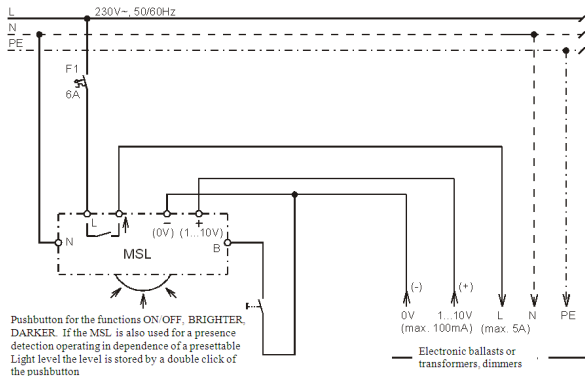

1 MSL for the functions light level reduction, lighting control or daylight dependent light level reduction with additional MSL-controls for the presence detection, with external pushbutton for the functions BRIGHTER/DARKER and ON/OFF. Optional with 1 pushbutton for the external control of the MSL

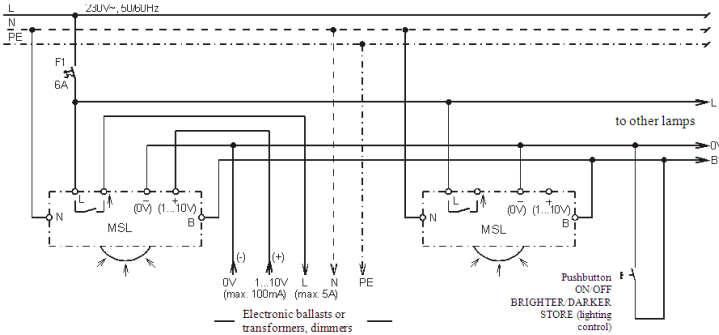

Several MSL modules with joint presence detection, each MSL provides for the light level reduction in its individual area, if one control however detects the motion, all lamps would go ON, also those in the areas of the other sensors.

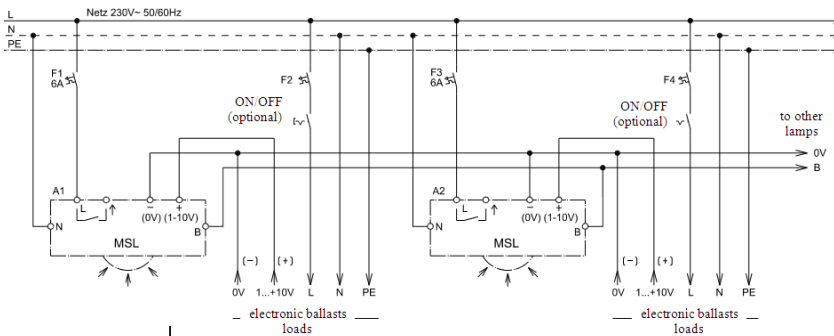

1 MSL for the presence detection. Switching of a non-dimmed load.

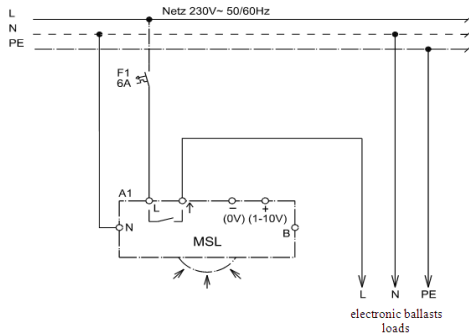

**Notes:**