

ALTOQUICK (AQ) 2,0 kW

for DIN-rail distribution boards



The ALTOQUICK-dimmer AQ 2,0 kW operates in the phase-control mode. It is equipped with harmonics filter and an interference suppression better than grade ,N' according to VDE 0875.

The AQ 2kW dimmer is suitable for incandescent lamps, high-voltage halogen lamps, low-voltage halogen lamps via wire-wound transformers and neon lamps via high- voltage transformers (please observe the power factor).

The AQ has a snap-on fastening device for standard C-profiled tracks according to DIN 46277.



Order-No.: 50.13.210

Operating with integrated potentiometer

The dimmer is switch ON by turning the rotary potentiometer from the OFF position to the right. The brightness of the connected load is adjusted with the potentiometer. The dimmer is switched OFF with the integrated switch by turning the potentiometer to the left.

Operating with external potentiometer

An external potentiometer can be placed in a distance up to 100m. When using an external potentiometer the switch at the AQ-dimmer must always be switched ON. The dimmer and its connected load consequently is not disconnected from the power supply. The disconnection has to be made between AQ-dimmer and supply. In this case the switch-contact of the potentiometer can be used for the operation of a contactor. For the control of a latching relay a rotary potentiometer with integrated pushbutton must be used. If a sliding potentiometer without integrated switch is used instead of a rotary potentiometer the ON/OFF switching is to be made with a separate switch.

Load amplification

Up to 3 AQ dimmers can be operated with one potentiometer without additional control. In this case the potentiometers in two dimmers are out of function. All 3 AQ's are commonly controlled with just one potentiometer. It has to be observed that the potentiometer switches in all connected dimmers are switched ON. If several AQ-dimmers are commonly being controlled, they can be distributed to different phases.

Up to 40 AQ-dimmers commonly can be controlled with one master control dimmer (type: AQS).

Within the range of load capacity the AQ-dimmers can be optional loaded.

ALTOQUICK (AQ) 2,0 KW

for DIN-rail distribution boards



Technical data

Type	: AQ 2,0 KW
Order-No.	: 50.13.210
Input voltage	: 230 V, 50 Hz
Nominal load	: 2,0 KW
Max. Output current	: 8,7 A
Protection	: external MCB's 10A
Minimum load	: incandescent lamps 60W inductive load 25W
Ambient temperature	: max. 45°C, natural cooling at vertical mounting
Terminals	: 0,5 – 2,5 mm ² , solid wires or litz wires with sleeve
Wire lengths	: max. 100 m
Power dissipation	: <1,5 % of the connected load
Control voltage	: 0...10V (0...20V) – directly disconnected No protective extra low-potential (base isolation according to IEC 664, 10/92)
Construction	: plastic housing with snap-on fastening for DIN-rails
Dimensions	: (WxHxD) = 175 x 85,5 x 75 mm
Weight	: approx. 600 gr
Noise	: < 40 dB (A) at nominal load in a distance of 1 m
Protective type	: IP 20
Contamination level	: 2 (dry, non-conducting, according to IEC 664, 10/92)
CE-requirements	: EMC complied according to EN 61547 4/96 Low-voltage according to IEC 669-2-1 11/94
Guarantee	: 24 months

When installing audio-systems basically the following has to be observed:

- Separate safety earthing for audio-transmission and dimming system have to be provided for.
- No parallel wiring between both systems allowed.
(please ask for detailed instructions).

Specification: www.altenburger.de

ALTOQUICK (AQ) 2,0 KW

for DIN-rail distribution boards



Dimensional drawing:

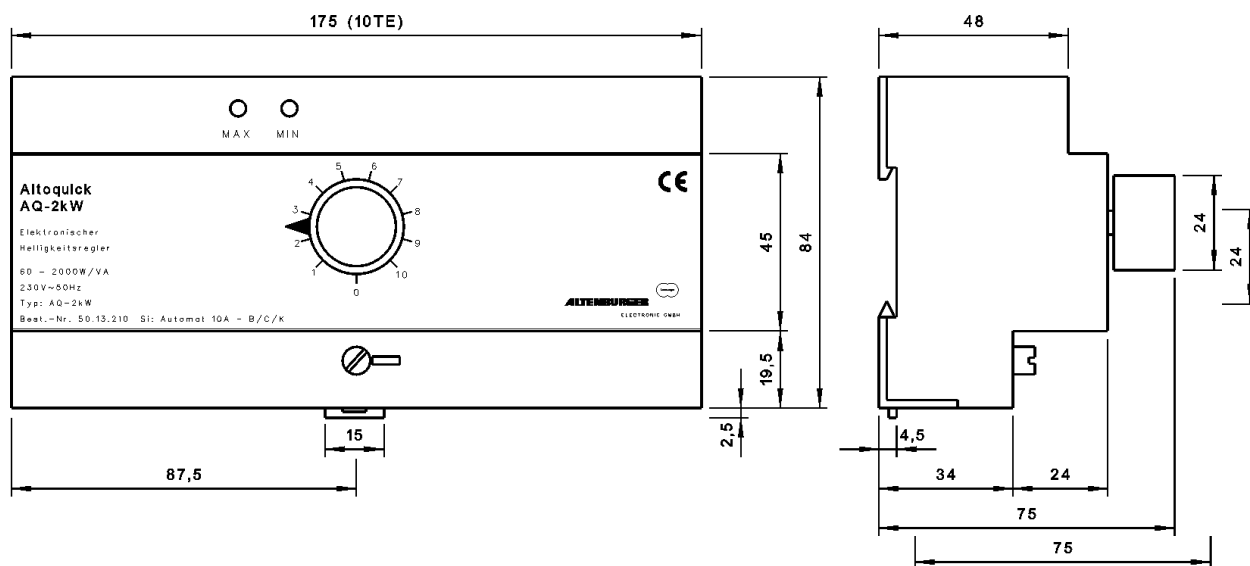

Wiring diagrams:

Incandescent lamps
high-voltage
halogenlamps

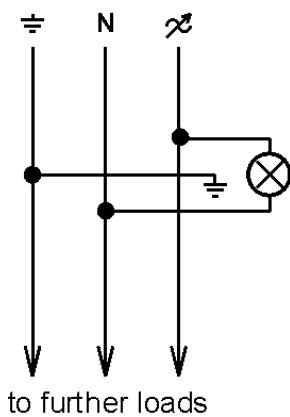

Low-voltage halogen
lamps with
wire-wound transformers

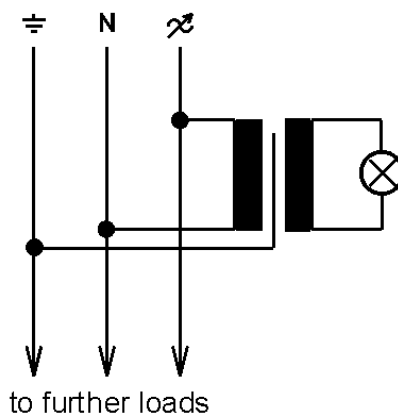

High-voltage
Neon lamps

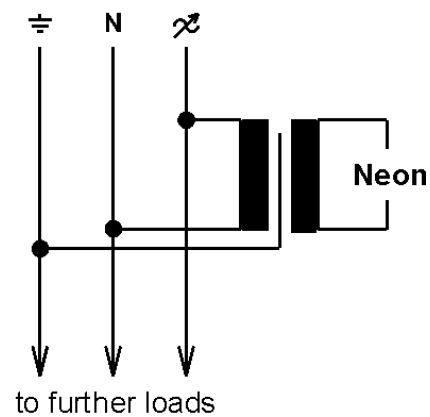

ALTOQUICK (AQ) 2,0 KW

for DIN-rail distribution boards



Wiring diagrams:

