

# ALTENBURGER ELECTRONIC GMBH

77960 Seelbach, Schloßweg 5, Tel.: 07823/509-0, Fax.: 07823/2761  
Internet: <http://www.altenburger.de>

## Operating instructions for the Light and Motion Sensor (active) LBS/de

### Area of application

The Light and Motion Sensor is designed for connection to lighting control unit with active sensor input. It is powered by the control unit and transmits motion signals and the brightness value needed for lighting control.

### Area of detection

The sensor has a motion detection angle of approx. 120°, covering an area with a diameter of approx. 6 to 7 m at a height of 3 m as depicted. The motion signal outputs of several sensors can be connected in parallel to increase the detection area or provide greater sensitivity. If the light value outputs of several sensors are connected in parallel an average value is used for determining the brightness level.

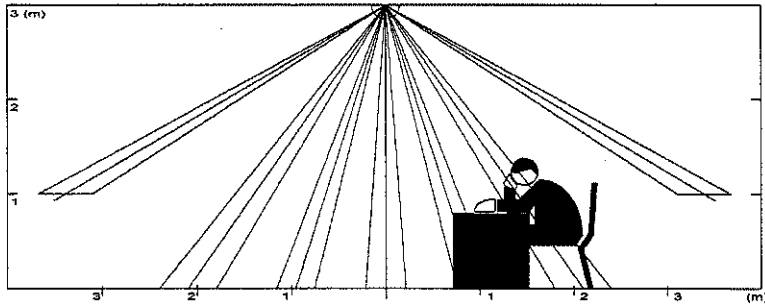

### Notes on installing the Light and Motion Sensor:

The sensor can be installed in the luminaire to be controlled or in the ceiling. With an adapter ring (as accessories), the sensor can be installed in a housing for 50 mm LV halogen lamps (halogen lamp mounting ring), so the unit can be easily installed in suspended ceilings. If the housing has a swivel insert, the angle at which the sensor is installed can be varied and therefore also the area of detection. If the sensor is to be installed in housings for halogen lamps with the aid of the adapter ring, you should first check the precise measurements as these may vary from manufacturer to manufacturer. Because the sensor has a side cable exit, not all halogen mounting rings are suitable for taking the sensor. It is best to check beforehand on an appropriate sample.

Wherever possible, the sensor should be installed so that it points directly at the area to be covered (e.g. working place). The sensor has to be installed near the controlled luminaires and should not be exposed to direct exterior daylight (e.g. close to a window) or to the light of separately controlled luminaires. The room brightness must be detected indirectly by the light reflected from a table surface or from the floor. The sensor optics are designed for a room height of between 2.5 and 3 m. Avoid placing the sensor in drafts (near a ventilator for example) or near equipment that gives off heat (such as a fax machine). The accuracy of control and the sensitivity of the motion detection will decrease with increased mounting height.

### Design and connection

The sensor has basic insulation (no safety extra-low voltage). It may only be operated on equipment designed for it. It must not be connected to mains voltage. The sensor is supplied with 2 m connecting cable. Check the relevant regulations for the particular area of application before installing, connecting or cabling the sensor.

#### Note:

For surface mounting on ceilings and installation in louvre luminaires we recommend using the LBS/d sensor, which has the same functions.

## Technical data

Designation:	Light and Motion Sensor (active)
Type:	LBS/de
Order-no.:	51.21.033
Operating voltage:	typ. 10V DC (8-20V DC)
Current input:	typ. 3mA DC
Operating temperature:	0°C to +50°C
Operating range:	up to 800 Lux at the sensor
Connections:	Vcc green (8-20V DC), 0V brown (ground), LS yellow (light value), B white (motion)
Connecting cable:	approx. 2m, ends stripped and tin-plated, 4x0.14mm <sup>2</sup>
Maximum cable length:	100m
Connection:	For wiring and parallel connection of sensors see control unit

- The sensor cables must be routed separately from DALI and mains cables (a shared cable must not be used) -

Protection class:	II (total insulation)
Type of protection:	IP 20
Pollution severity:	2 (dry not conductive)
Dimensions, weight:	See diagram, approx. 65g
Design:	Plastic casing
Accessories:	Adapter ring Ø50mm for installation in a housing for 50mm LV halogen lamps
Labelling:	CE

- If incorrectly connected there is a risk of failure or destruction -

## Safety and installation instructions

- The unit should be installed and tested only by a qualified electrician.
- Power to the units must be switched off before any work is undertaken.
- The relevant safety and accident prevention regulations and installation instructions to be observed.
- UV-resistant cables must be used if they are exposed to light from the lamp.

## Dimensional drawing:

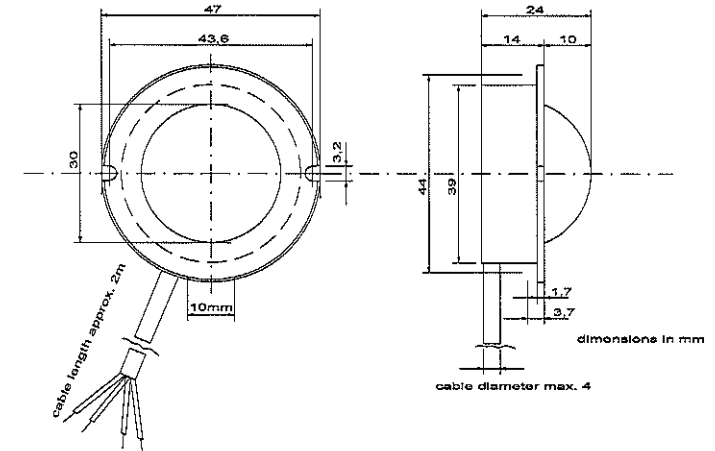

27.07.2007 V1.1

Subject to change without notice. Errors and omission excepted.